

Doctor Octopus

Use a really large, thin sheet of tissue foil.

5 September 2004

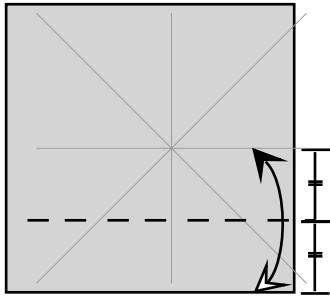

1. Start with the coloured side up. Fold and unfold.

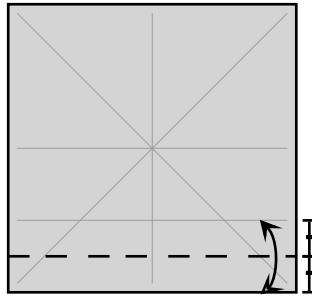

2. Fold and unfold.

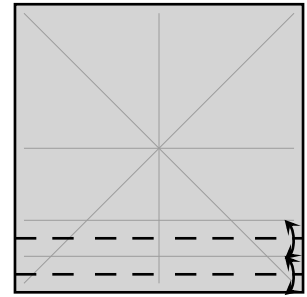

3. Fold and unfold.

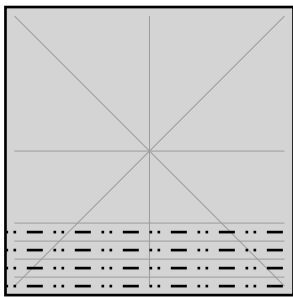

4. Fold and unfold.

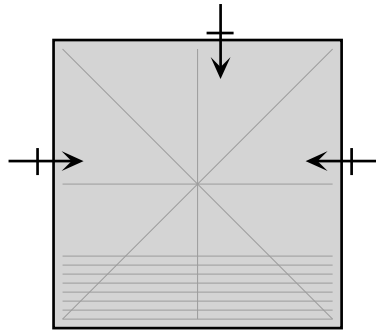

5. Repeat steps 1-4 on the other three sides.

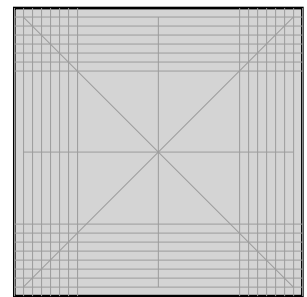

6. In the next few steps, not all the crease lines will be shown.

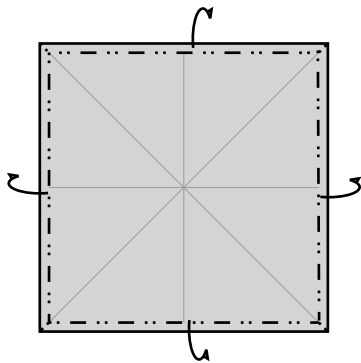

7. Mountain fold along the outermost crease line. Pull out the corners.

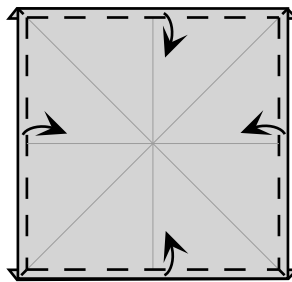

8. Valley fold along the next set of creases.

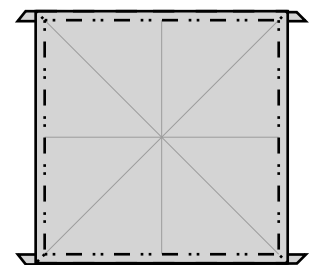

9. Repeat steps 7-8 until you run out of precrease lines.

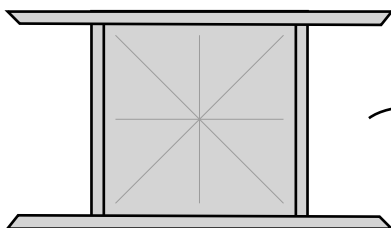

10. Turn the model over.

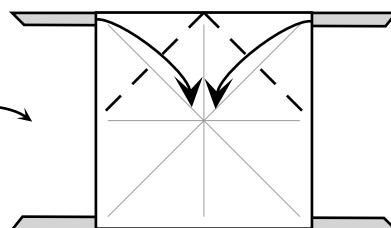

11. Valley fold.

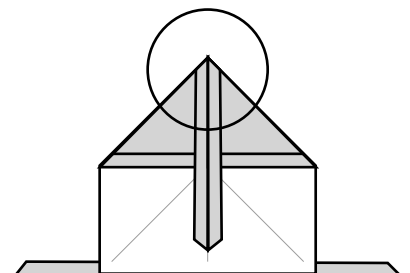

12. The next few steps will focus on the vertex.

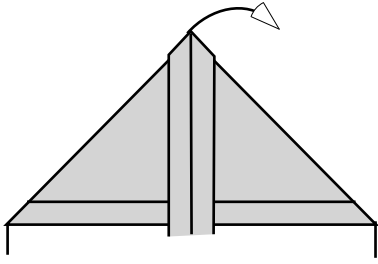

13. Unfold the pleats at the top.

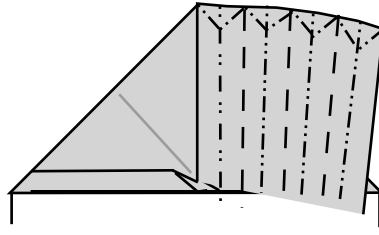

14. Refold the pleats, incorporating the squash folds shown above.

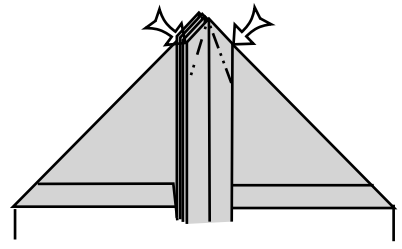

15. Open sink along the angle bisectors of the top layer.

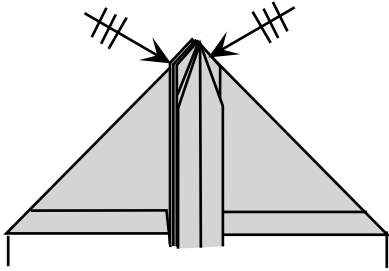

16. Repeat the previous step on the rest of the layers.

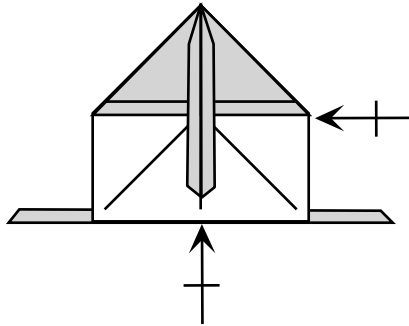

17. Repeat steps 12-16 on the bottom, and 13-16 on the right.

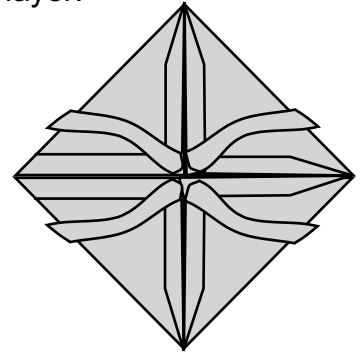

18. The tentacles will in general not lie flat, so move them out of the way when the need arises.

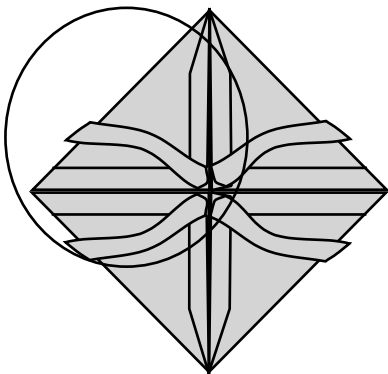

19. The next two steps focuses on a single tentacle.

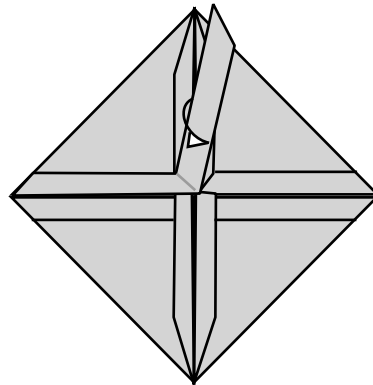

20. Wrap a single layer around.

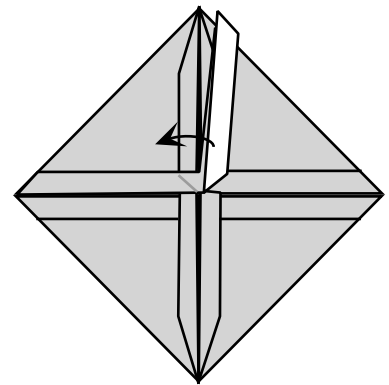

21. Fold the tentacle to the left.

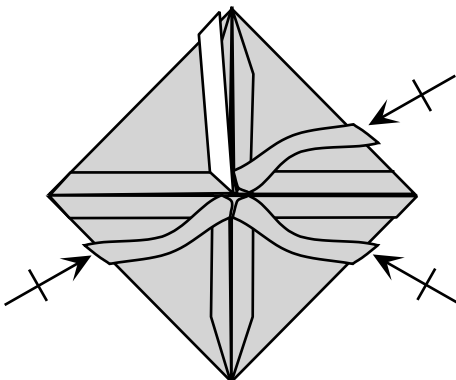

22. Repeat steps 20-21 on the other three tentacles.

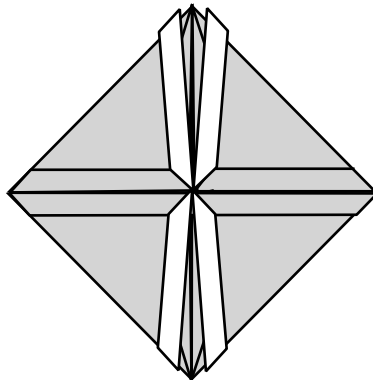

23. For clarity, the tentacles will not be shown in the next several steps.

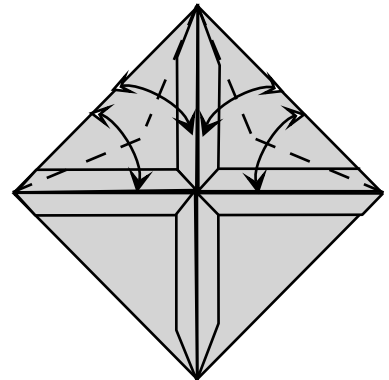

24. Fold and unfold along the angle bisectors.

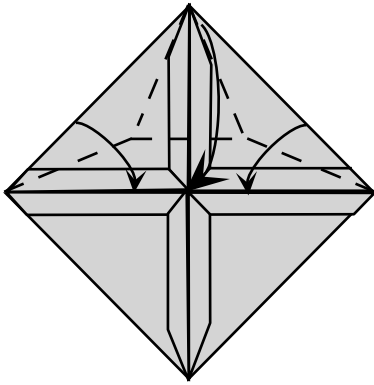

25. Fold the flap down.

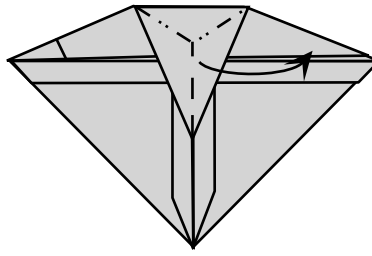

26. Swing the flap to the right.

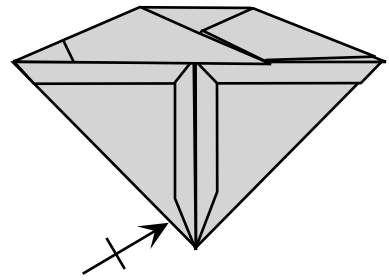

27. Repeat steps 25-26 on the bottom.

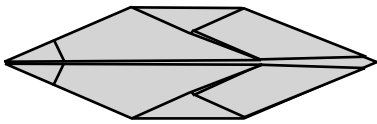

28. Rotate the model counterclockwise.

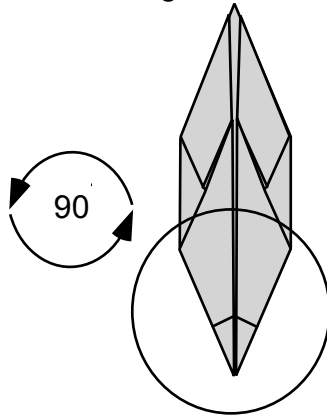

29. The next few steps involve splitting the bottom point to form the feet.

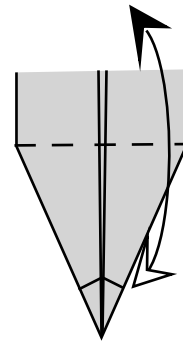

30. Fold and unfold.

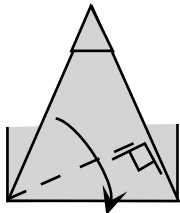

31. Valley fold.

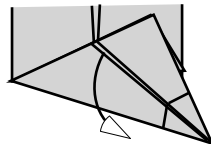

32. Pull out paper.

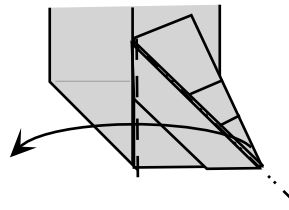

33. Squash fold the flap to the left.

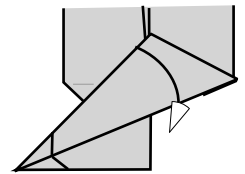

34. Pull out paper.

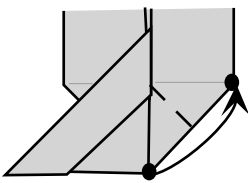

36. Valley fold. The flap will not lie flat.

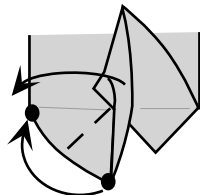

37. Intermediate 3-d step. Open out the flap and flatten.

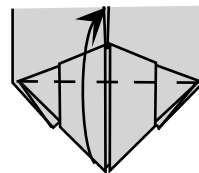

38. Valley fold.

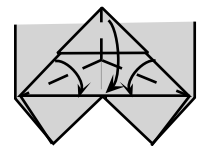

39. Rabbit ear.

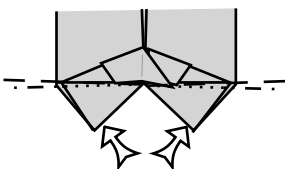

40. Reverse folds.

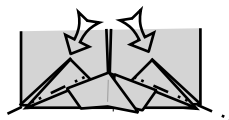

41. Reverse folds.

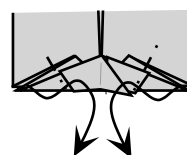

42. Reverse folds.

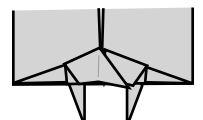

43. The feet are done for now.

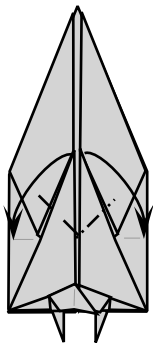

44. Valley fold the arms.

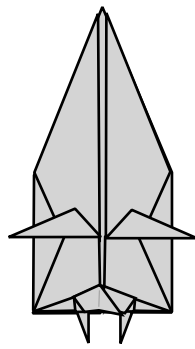

45. Turn the model over.

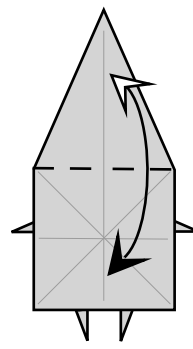

46. Fold and unfold.

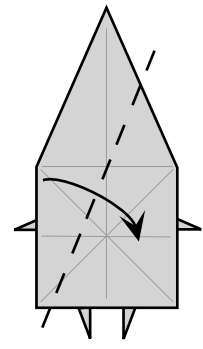

47. Valley fold (no landmarks).

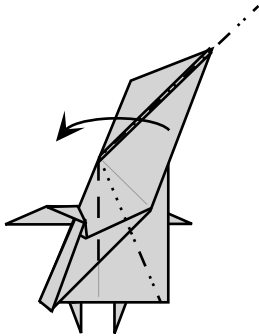

48. Fold over to the left.

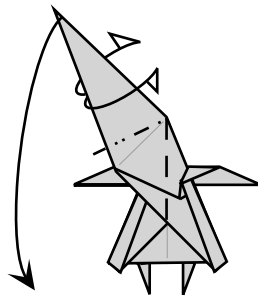

49. Squash fold.

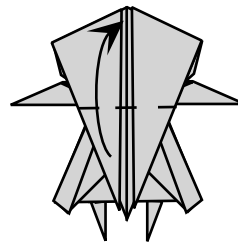

50. Valley fold (no landmarks).

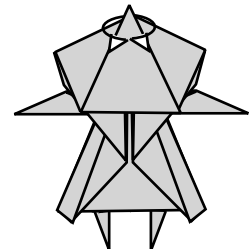

51. Fold the topmost point down (the sides will be wrapped around).

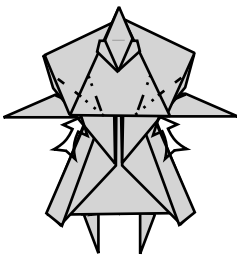

52. Reverse folds.

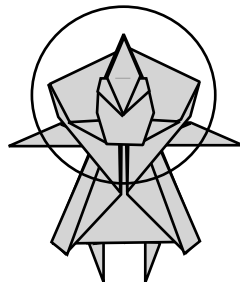

53. Head details.

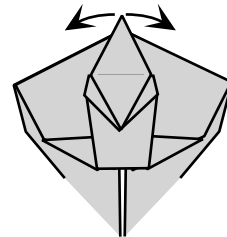

54. Spread the points.

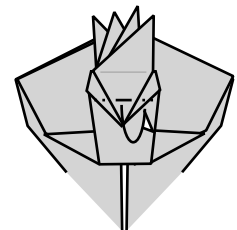

55. Mountain fold.

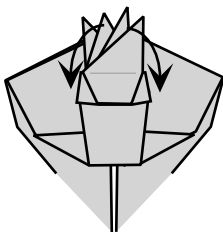

56. Fold the points down.

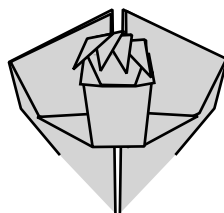

57. Finished head.

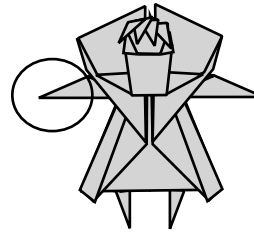

58. Hand details.

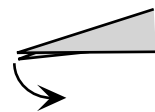

59. Spread the points.



60. Crimp.



61. Finished hand. Repeat on the other hand.

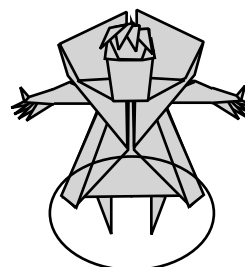

62. Feet details.

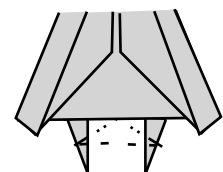

63. Crimp.

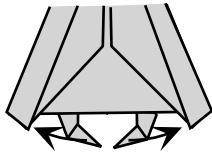

64. Bend the legs outwards and spread the feet.

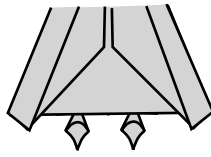

65. Finished feet.

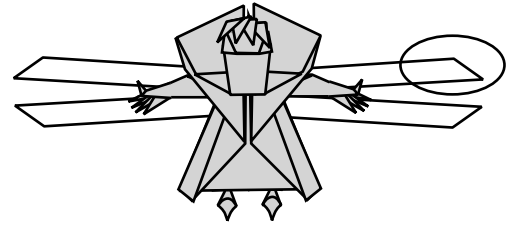

66. Claw details.

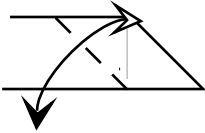

67. Fold and unfold.

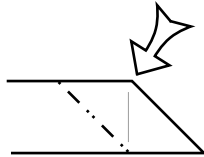

68. Close sink.

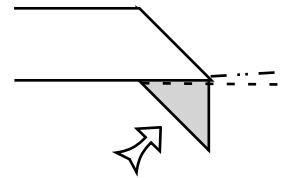

69. Reverse fold.

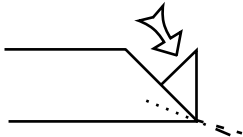

70. Reverse fold.

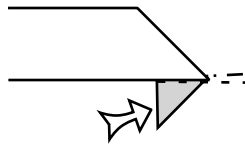

71. Reverse fold.

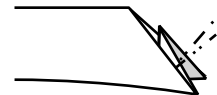

72. Reverse fold.

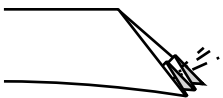

73. Reverse folds.

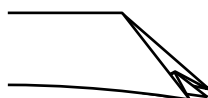

74. Finished claw. Repeat on the other three claws.

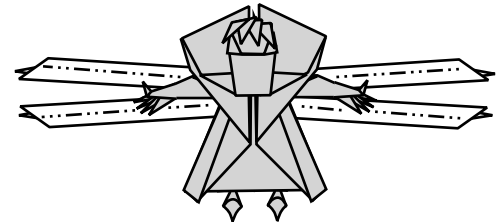

75. Mountain fold in half (or thirds) to narrow the tentacles.

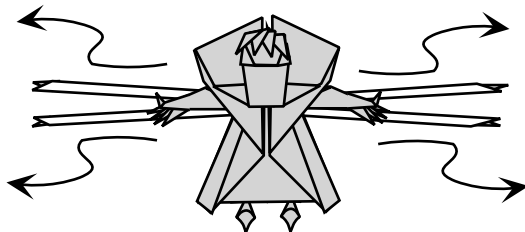

76. Shaping:
 (a) Curl the tentacles and spread the claws.
 (b) Shape the arms and hands.
 (c) Shape the body.

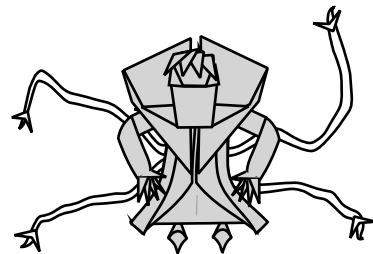

77. Finished.

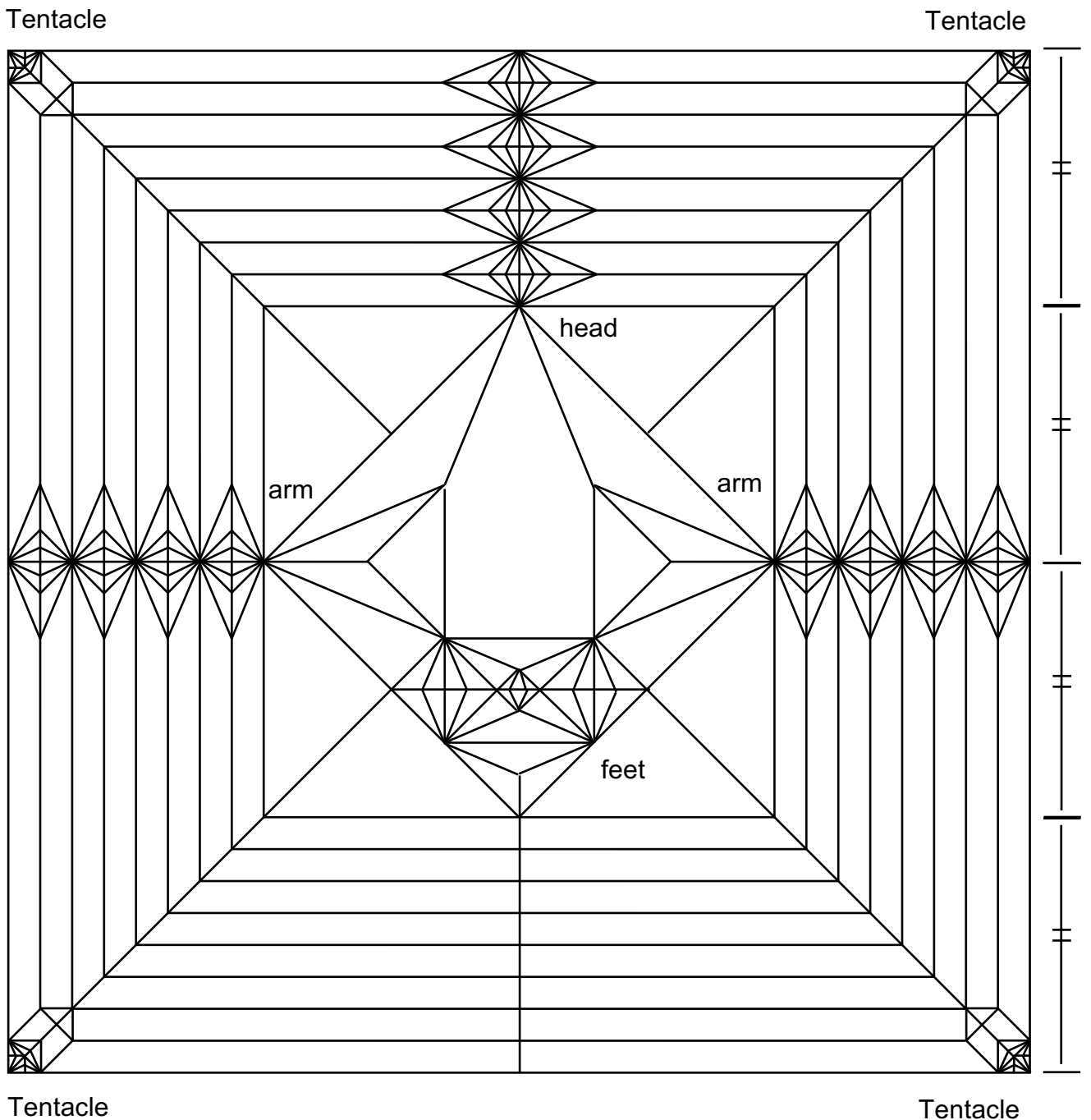

Essentially a bird base with 4 edge grafts. In principle, the length of the tentacles can be increased indefinitely by reallocating more paper to the edge grafts, and pleating as often as necessary to obtain the desired aspect ratio. In practice, the paper thickness becomes the limiting factor; you can only pleat it so many times before it gets too thick to handle.